



# COMPANY PROFILE & PRODUCT RANGE

Trioliet. Invents for you.

***“Trioliet has  
the right  
solution  
for every  
livestock farmer”***

 *Walter Truitman | Dairy farmer*



## THE LARGEST SELECTION OF MIXER FEEDERS

*As a specialist in premium feeding technology, Trioliet has the most extensive range of mixer feeders, feeding robots, self-propelled mixer feeders and stationary mixers. We have the right solution for every livestock farmer and every business situation anywhere in the world.*

- Page 4** Understanding feeding
- Page 10** Quality and innovation
- Page 18** Corporate social responsibility
- Page 24** Unique characteristics of Trioliet mixer feeders
- Page 26** Product overview
- Page 42** Service and maintenance
- Page 44** About Trioliet
- Page 46** Trioliet sales organisation and contact details



*Your cows should receive balanced rations every day to remain healthy and to be able to perform at their best. It is thus important to focus on a good mix quality and good feed management. But this takes time.*

Accurate feeding is, in fact, an important but time-consuming task in the farming business. Trioliet can help you with this. Our feeding systems are made in a way that enables you to prepare the best meal for your cows without any additional effort. Still unsure which system is best for your needs? We can help you choose a feeding system by carefully examining your personal situation. With more than 75 years' experience, we know what is good for you and your animals and we are confident enough to say that we understand feeding.



# UNDERSTANDING FEEDING





**- *Cows should receive balanced rations every day***





### PREVENT FEED SELECTION

A well-known phenomenon at many dairy farms is that cows move their noses through the rations in order to try and extract the tastiest feed. This is not a desirable situation. Dairy farmers spend a great deal of time determining the best rations, and selection behaviour may leave the most important components lying at the bottom of the feeding fence. This comes with a host of consequences, including lower feed efficiency, ruminal acidosis

and other health problems. So how can we stop cows from selecting their food at the feeding fence? The answer is simple: with optimal mixing.

Dairy farmer Bert Versteeg, together with his wife Anja and son Robert, runs his farm, which has 120 dairy cows and 60 young cattle. Last year Versteeg was informed by his feed adviser that the feed selection could be cut back further, in spite of the fact that the yield

# THE CORRECT LOADING ORDER IS IMPORTANT

Bert Versteeg | Dairy farmer

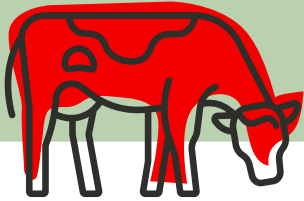

**120 dairy cows**

was absolutely fine based on an average of 27 kg (60 Lbs) of milk per cow per day. It was the start of a valuable process that offered new insights and new practices. Bert Versteeg: “The feed looked well mixed to me, but the consultant was not satisfied. Apparently, the cows could still select too much.”

The loading order and other factors were changed to ensure homogeneous mixing of the feed. Instead of loading the concentrate feed first, Bert Versteeg now starts by filling the mixer wagon with grass. Versteeg: “I first load the grass silage and then add a proportion of the maize. I mix that for about 15 minutes and I then add water and concentrate feed.” Loading the mixing tub with the textured grass and a little maize first makes it easier for the two augers to process the compact feed and for the auger knives to do their job. The finer concentrate components are not added until the grass has been cut and separated properly. Versteeg: “The new loading order makes it a lot easier to mix the rations and also requires less tractor power.”



For more stories, check out our blog

[www.trioliet.com/blog\\_stories](http://www.trioliet.com/blog_stories)

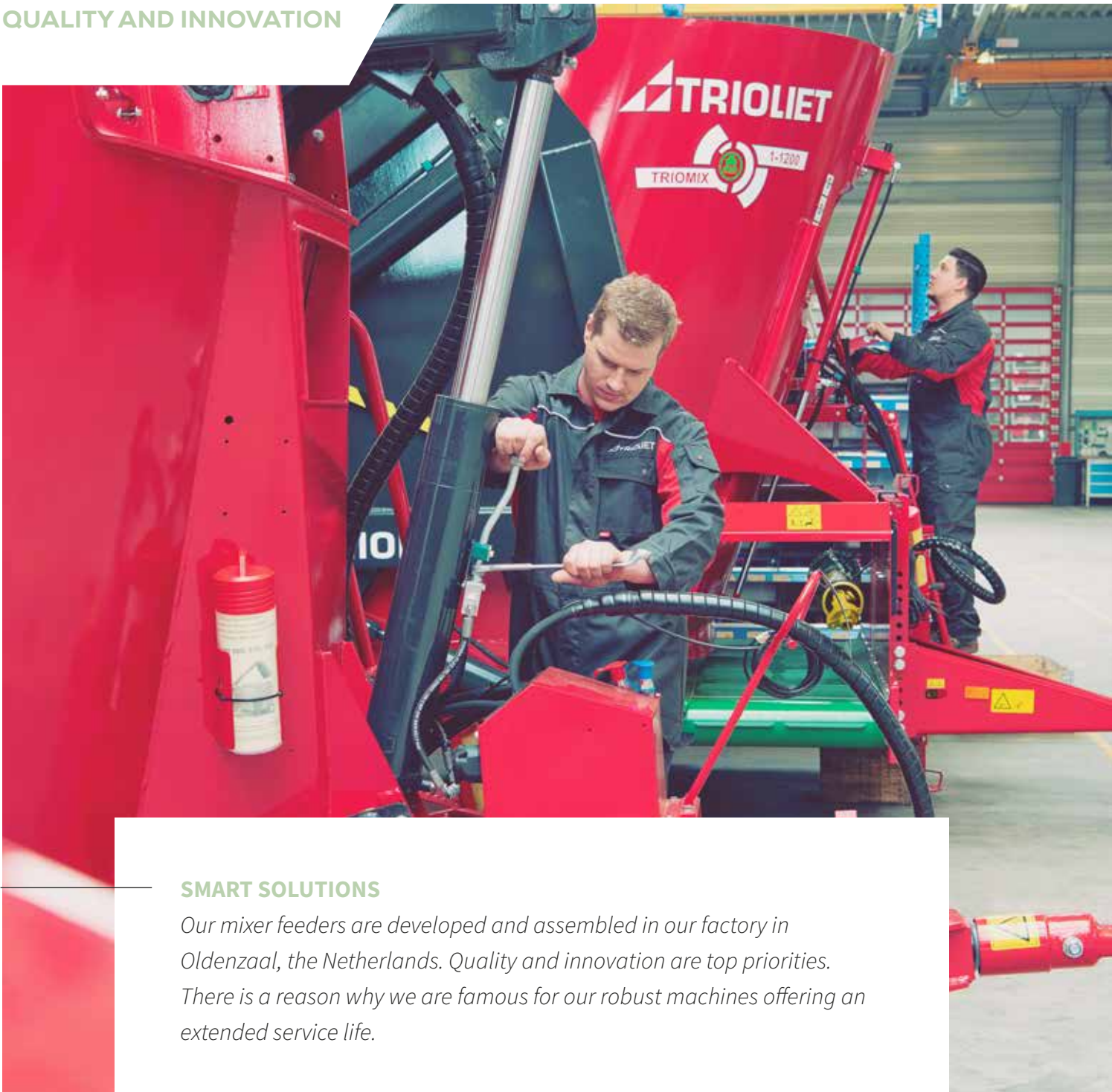

### SMART SOLUTIONS

*Our mixer feeders are developed and assembled in our factory in Oldenzaal, the Netherlands. Quality and innovation are top priorities. There is a reason why we are famous for our robust machines offering an extended service life.*

You are guaranteed a quality product when you choose Trioliet. We excel in technical ingenuity. That's why we have more than sixty patents to our name. Our R&D department consists of highly qualified engineers with an understanding of mechanical engineering. They have strong ties to the agricultural sector. That means we are always developing from the perspective of the user. New machines are thoroughly tested before they go into production.

Every day, about 400 employees work on the development, assembly and sale of our feed systems both at its headquarters in the Netherlands and in the field, at home and abroad.



**RUNNING THROUGH  
EVERYTHING IS A  
STRONG SENSE  
OF A PROUD FAMILY  
BUSINESS**



## A GLOBAL PLAYER



About 85% of the machines are exported to more than 50 countries. You can find Trioliet feed machines in Germany, the United States, Mexico, Uruguay, Chile, Saudi Arabia, France, Ireland, China, Norway, Canada and Australia, to name but a few.

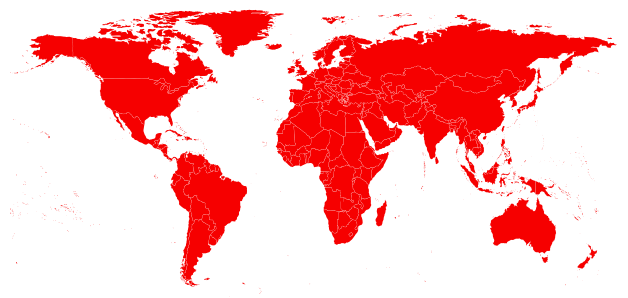

- *Every day millions of cows all over the world are fed with our machines*

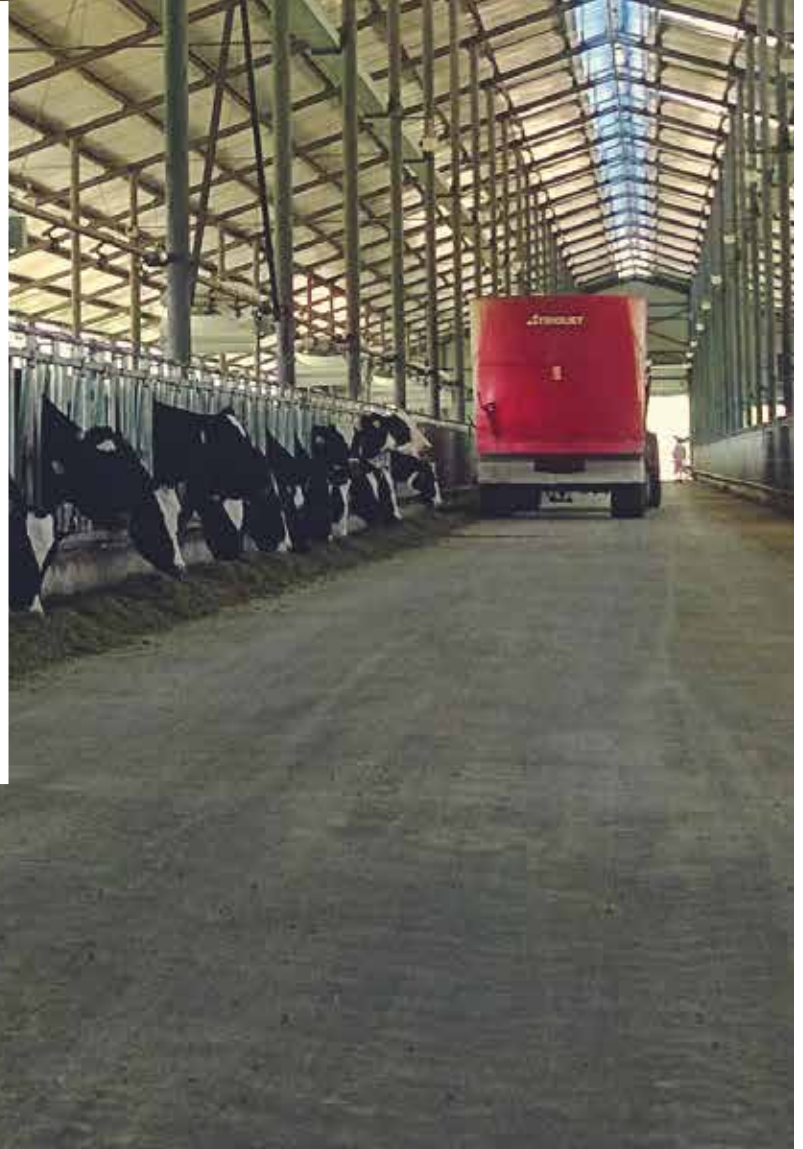



*Turbobuster silage cutter*

### A FEW UNIQUE TRIOLIET INVENTIONS:

#### TU SILAGE CUTTER

The TU silage cutter as we know it today was first developed by Trioliet in the 1980s. The U-shaped cutting frame was revolutionary in that it cuts out a large block of feed in one go. This robust silage cutter has always been a steady help for many farms.

#### 'DUAL FLOW' MIXING TUB

Thanks to the innovative design of the mixing tub in the Trioliet mixer feeder with 2 or 3 mixing augers, the feed is mixed both vertically and horizontally according to the 'Dual Flow' principle. The feed is pushed (vertically) upwards by the specific auger shape of the Twin Stream mixing auger and gravity ensures that the feed then falls downwards. The mixing tub is fitted with patented offset inserts so that the feed is transported horizontally through the entire tub. This 'Dual Flow' principle results in a perfect mixing result, thus preventing the cows from being able to select only the tastiest feed.

## WEAR RING

The pressure on the wall is at its greatest at the bottom of the mixing tub of the mixer feeder. That's why we have made a ring at the bottom out of thicker steel, thus ensuring a high level of wear resistance. This unique wear ring ensures greater stability and a longer service life.

## TWIN STREAM AUGERS

The Trioliet augers have a slim shape, which is in an optimal ratio with the mixing tub. This shape enables us to achieve an optimal mixing result, and even small quantities of feed are homogeneously mixed without any problem.

## TRIOFORM AUGER KNIVES

The Trioliet auger knives are also unique in shape. The knives are self-sharpening and save fuel thanks to their aerodynamic design. It is important to keep the auger knives in good condition. Sharp knives ensure better mixing and use less power. This results in a longer service life and saves on fuel costs. You should therefore check regularly whether the knives are still in good condition. The knife positions on the auger are also important for a well-mixed ration. The required positions of the assembled auger knives depend on the composition of the ration and the type of mixer wagon.



*Twin Stream auger*

## UNIVERSAL CUTTING SYSTEM

The universal cutting system on our self-loading machines requires only a small amount of power and consumes less fuel than an alternative discharge system. The Trioliet cutting system also leaves the feed structure intact, which remains unaffected (unlike with a mill). Moreover, the silage clamp remains smooth and sealed after silage extraction. This prevents oxygen from getting into the silage, thus maintaining the feed quality.

## SHIFTRONIC

The Shiftronic is a reduction gearbox that – depending on the load – automatically changes gear based on the optimal power requirement. This prevents overloading in the drive line of both the mixer feeder and tractor and thus also saves diesel (all fully automatic).

# THE TRIOTRAC DOES NOT REQUIRE A LOADING DEVICE OR A TRACTOR FOR FEEDING



*The Triotrac is the self-propelled mixer feeder with the highest loading capacity in the world.*





# - *Trioliet would like to contribute to a better environment for both people and animals*



## **TRIOLIET SUPPORTS FAMILIES IN AFRICA WITH MICROFINANCING FOR COWS**

*Trioliet and the Farm Friends Foundation work together on the 'Cow Lease' project to improve the lives of cattle farmers in Africa. Through these cow-financing initiatives, which are then paid off in instalments by the African farmers, the two organisations hope to boost the economic position of African families.*

For African farmers, a cow is a valuable asset. It provides milk, rearing and manure and is a financial reserve. Milk is a high-value foodstuff and, particularly for children, is an outstanding supplement to their diet. The cattle farms in Africa consist mainly of families with one or two cows and, unlike here, it is often the women who run the farm. As part of the 'Cow Lease' project, the farmers' wives borrow money

for a cow in calf, which is provided by the Farm Friends Foundation. The Foundation provides experience and expertise in cattle farming to the local farmers and offers them tips on how to achieve higher milk production. In addition, they are given advice on how to become self-sufficient. We have now helped 2,500 farmers in Tanzania in this way. They are self-sufficient and no longer need help from Farm Friends. Robert Liet, Director of Trioliet: "We fully support this initiative to give the local economy a boost and at the same time help families to generate income." It's a really great project in which we can pass on our knowledge about feeding."

## SUSTAINABLE BUSINESS

Our aim in everything that we design and produce is to be of service to the livestock farmer. Saving labour, time and fuel, maintaining a healthy herd and the perfect mixing quality are just some of the priorities that we focus on. We pay careful attention to the environment and living conditions. The products, which make a significant contribution to

sustainability, are awarded the Green Label quality mark. Take, for example, the fuel-saving Shifttronic reduction gearbox, the Trioliet cutting system or the dust-reducing water injection system on our straw blowers. You can identify the Green Label quality mark by the green sticker on the machine.





### PREVENT HARDWARE DISEASE

Each year, an estimated 12,000 cows in the Netherlands alone are injured by ingesting litter that has entered their feed. Another four thousand cows die as a result of hardware disease. Wageningen University & Research looked into the effects of litter, concluding that hardware disease costs dairy farmers approximately EUR 14 million each year in medical treatment, death and reduced milk production. However, there is a solution many dairy farmers are not aware of: magnets in the mixer feeder wagon.

#### MAGNET ON THE AUGER

Pim Lenferink knows that magnets can prevent a lot of injury. Since last year, he has been feeding 135 dairy cows with a Trioliet mixer feeder, which is fitted with auger magnets.

He was not aware of this product until his dealer explained he could place magnets on the augers. It was a purchase he definitely does not regret.

He shows his 'harvest' on the kitchen table, picking out the most striking objects. This includes nails, barbed wire and screws. But other, sometimes indefinable, metal objects are also included in the collection. Some have extremely sharp edges and are as long as a ballpoint pen. It is clear that these objects could most certainly injure a cow. "Within a month we collected around thirty objects", explains Pim Lenferink. "Every day we find sharp metal objects on the magnet. We were so impressed that we immediately installed a magnet on the second auger."

## BIRDS COULD BE THE CULPRITS

How these metal objects enter the feed is shrouded in mystery. Pim: “They could be thrown by school children or passing motorists. But we have also heard that crows pick up these types of objects to build their nests and then drop them because they’re too heavy. Whatever it is, this collection is certainly food for thought. I didn’t know beforehand what the results would be.”

“But I cannot imagine that other farmers are able to filter out all the sharp objects when preparing silage. After all, you can’t know what you don’t see. People often think they will find sharp objects in grass silage, but what about the by-products and the hay and straw bales?”

Lenferink recently made a striking discovery. The magnets were covered with a thick layer of metal grit – extremely small particles of metal, most probably from a batch of purchased concentrate feed. Pim: “This doesn’t immediately cause damage, but it shouldn’t be in there. We would never have been able to retrieve it without the magnet. That just goes to show how important the magnets are. As far as I am concerned, this should be a standard feature of every mixer feeder wagon, as it saves a great deal of animal suffering.”



For more stories, check out our  
blog: [www.trioliet.com/blog\\_stories](http://www.trioliet.com/blog_stories)

# MAGNET IN MIXER FEEDER PREVENTS A GREAT DEAL OF ANIMAL SUFFERING

Pim Lenferink | Dairy farmer

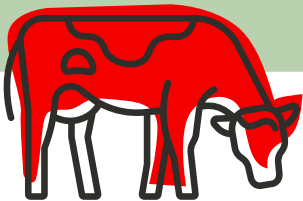

**135 dairy cows**



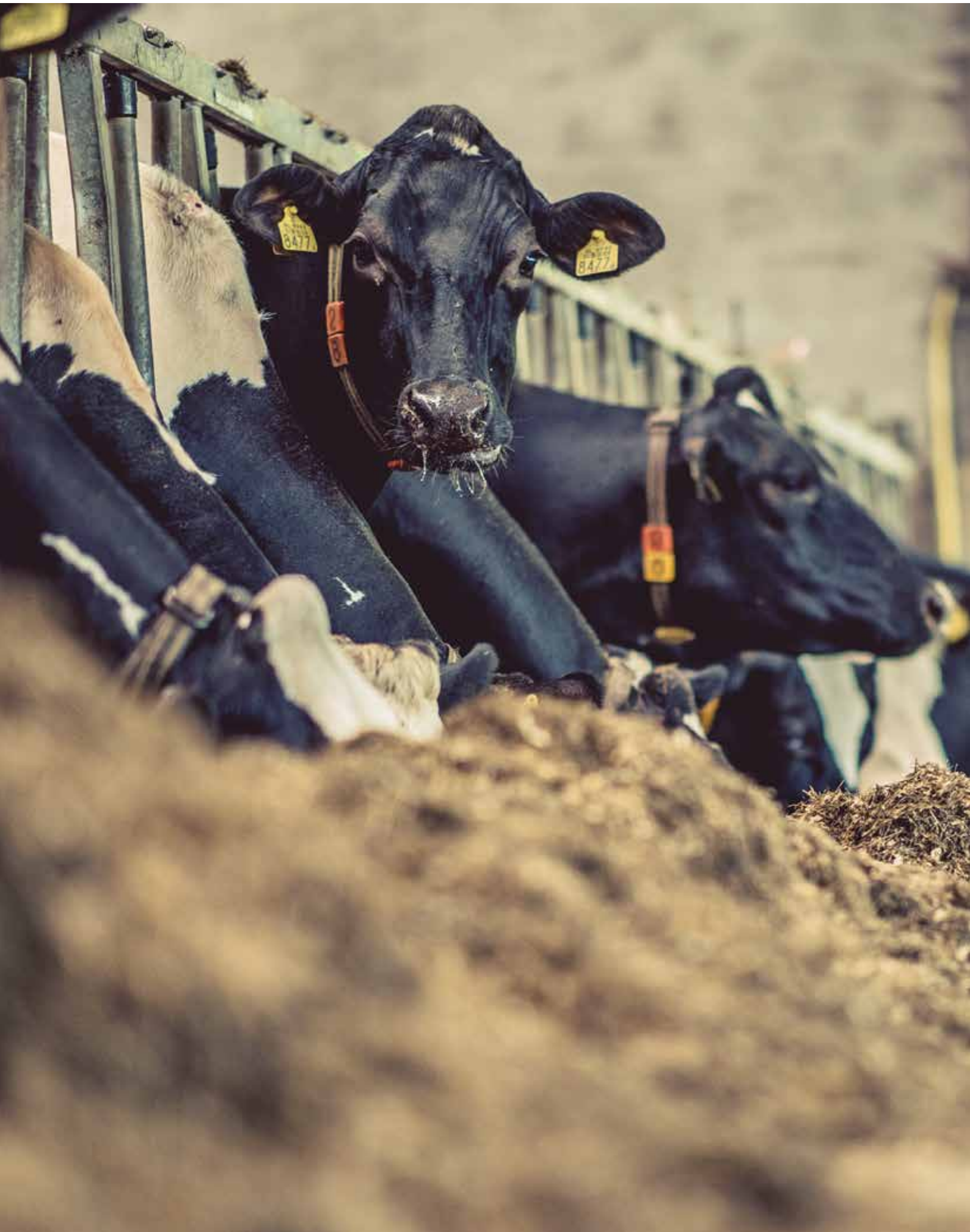



***As well as feed efficiency, the ration also has a major impact on the general health of the cow***

## UNIQUE CHARACTERISTICS OF TRIOLIET MIXER FEEDERS

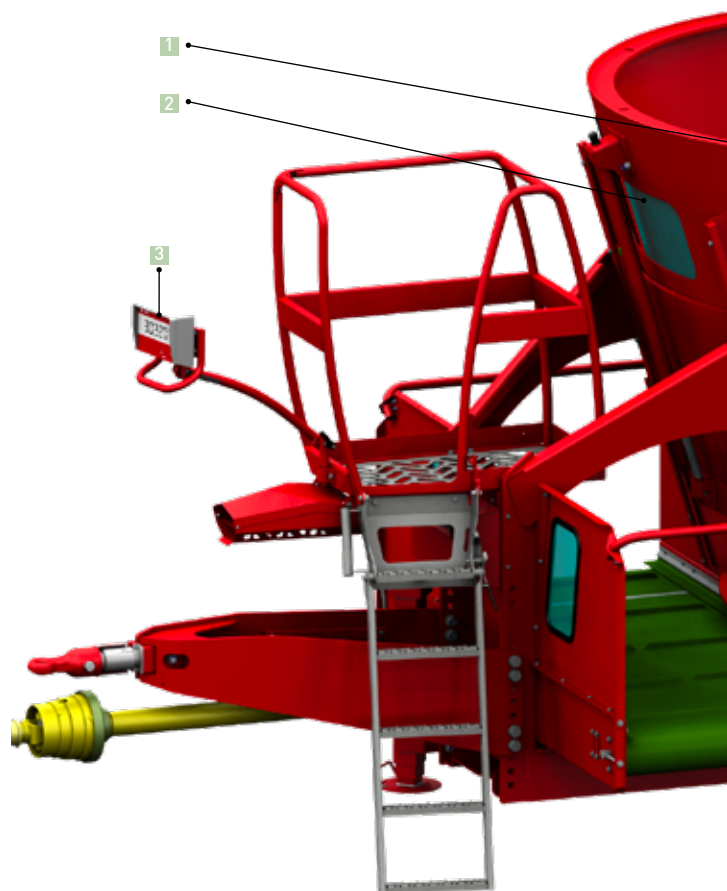

**1 Unique mixing tub with “Dual Flow” system for the perfect feed mix** | The asymmetrically fitted inserts also force the feed into being mixed horizontally. This delivers optimally and evenly mixed rations and rapid, uniform feed discharge.

**2 A large window for an excellent view of the mixing process**

**3 Unique weighing system** | Three robust weighing bars ensure maximum stability. Thanks to a dual measurement per weighing bar, the weight is displayed with extreme precision. The illuminated weight indicator is effectively screened off in an impact-resistant, waterproof enclosure.

**4 Unique auger bearings** | When mixing feed, large sideways and vertical forces act on the auger(s), particularly when round bales are being processed. The large bearing distance and the robust top bearing inside the auger guarantee optimal stability and an extended service life.

**5 Slim, stable auger column** | The slim auger column is extremely stable, as it is directly supported by the chassis under the floor.

## WATCH OUR VIDEO:

"HOW TO OPTIMISE MY MIXER FEEDER" AT  
[TRIOLIET.COM](http://TRIOLIET.COM)



**6 Trioform auger knives save fuel** | The patented shape of the Trioform auger knives reduces resistance. This results in fuel savings. Moreover, the knives are self-sharpening and thus durable during operation.

**7 Specially welded augers** | The augers are stronger thanks to their overlapping construction (longer service life).

**8 Twin-Stream augers for improved feeding** | The slim auger body and large auger surface area ensure an optimal fill factor and rapid, homogeneous mixing. The two symmetrical auger wings ensure rapid, even feed discharge - even in the case of small mixes.

**9 Strong, stable mixing tub** | Trioliet has the mixing tub at the bottom where the pressure on the mixing chamber is at its greatest. It is fitted with a special wear ring. This ensures greater stability and a longer service life.

**10 S355JR (St. 52)** | All Trioliet mixer feeders (tub, auger(s), chassis and wear ring) are manufactured out of S355JR (St. 52).

# SOLOMIX MIXER FEEDERS

Mixer feeders with 1, 2 or 3 vertical augers



Solomix 2

*We have an extremely extensive range of mixer feeders. Our Solomix series consists of more than two hundred different types. We're almost certain that we have the right solution for you.*

Our mixer feeders are available in different sizes, with capacities varying from 5 to 52 m<sup>3</sup> (180 - 1,860 cu.ft.). Depending on the capacity, the mixer feeder will have 1, 2 or 3 Twin Stream augers.

The mixing tub of the 2- and 3-auger machines has a unique design, ensuring the feed is transported both vertically and horizontally through the tub (the so-called 'Dual Flow' principle). As a result, the various feed components are mixed extremely well together.



Solomix 1



Solomix 3



### YOU CAN CHOOSE FROM A RANGE OF DISCHARGE UNITS:

- ▶ *B: Cross conveyor belt*
- ▶ *K: Cross conveyor chain*
- ▶ *C: Curved cross conveyor chain with side-shift*
- ▶ *S: Cross conveyor chain with retractable extension chain for feeding in troughs*
- ▶ *ZK: Discharge doors*

The capacity and discharge unit that is most suitable for you depends on the conditions on your farm. The size of your stable is also of critical importance.

### OPTIONS AND PREFERENCES

A variety of options are available, e.g. a straw blower, a hay ring or a magnet. Please don't hesitate to ask about the available options.



Solomix P

# SILAGE CUTTER FEEDERS

*Self-loading feeders*



*No need to mix, but want to efficiently move the feed from the silage to the stable? If so, one of our silage extraction and discharge machines is an excellent choice.*

Our silage extraction and discharge machines are compact, self-loading feeders that do not mix the feed. Different types are available; ones with a U-shaped cutting frame, cutting board, crab board or loading platform. All are versatile machines that help you to streamline the feeding process and transport the feed from the silage to the stable without spilling any of it.

Did you know that Trioliet is the inventor of the U-shaped silage cutter?



# SELF-LOADING MIXER FEEDERS

Mixer feeders with a cutting- loading system.



We have different types of self-loading mixer feeders in our product range. You can choose from a self-loading system with an active cutting or a fixed stationary knife. A self-loading mixer feeder with a crab board or a loading platform is also available.

The extraction systems of our self-loading mixer feeders consume much less fuel compared to self-loading mixer feeders with a milling system. Moreover, the feed structure is retained.

- ▶ *Gigant: with cutting or crab board*
- ▶ *Triomix: with its active cutting unit or a fixed stationary knife*
- ▶ *Vertifeed: with loading platform*

The advantage of a self-loader is that no additional loading device is needed for silage extraction and loading.



# TRIOTRAC SELF-PROPELLED MIXER FEEDERS

*Unique thanks to the cutting-loading system*



*Triotrak X*

*You invest a great deal of time and energy into silage extraction of the forage. That's why it is also important that the quality of the feed continues to be maintained. The silage extraction method is extremely important here.*

With a Triotrak self-propelled mixer feeder you do not need a loading device or a tractor for feeding. This mixer feeder is fitted with a cutting system. The Trioliet silage extraction system leaves the feeding structure intact so that the nutritional values are retained, unlike a milling system, which virtually pulverises the structure of the feed.

We have self-propelled mixer feeders of between 14 and 32 m<sup>3</sup> (500 - 1,160 cu.ft.) in our range. The Triotrak is the self-propelled mixer feeder with the highest loading capacity in the world. It can process up to about 2,500 kg (5,510 Lbs.) of grass and 3,500 kg (7,715 Lbs.) of maize per minute. The cutting-loading system of the Triotrak leaves a perfectly straight-cut silage wall behind it.



*Triotrak M*

The telescopic loading arm can be positioned up to a height of eight meters (27 ft) above the silage at the correct angle and cut the silage in a perfectly straight manner. This ensures that the silage is not able to heat up and that there is virtually no loss of crop. The loading system is capable of loading all types of feed very quickly and accurately, including round or square bales.



Triotrac L

If you think that good feed structure and rapid operation are important, our self-propelled mixer feeders are ideal for you.



Triotrac M

# TRIOMATIC AUTOMATIC FEED SYSTEMS AND FEEDING ROBOTS

*Widest choice of automatic feeding systems*



Triomatic WP 2300

*Do you attach value to accurate feeding, efficient use of time and the well-being of your animals? If so, the Triomatic automatic feeding system is ideal for you.*

With four types of feed kitchen and three types of feeding robot available, we have as many as twelve automatic feeding systems in our product range. You can choose from a hanging or wheeled feeding robot and a feed kitchen for loose components for blocks or round bales. Some feed kitchens have a storage capacity of up to five days. Changes to the ration can also easily be made using a smartphone, tablet or PC.



Battery robot WB2300



Triomatic T40



Triomatic T30



Want to know more about the Triomatic automatic feeding system? For user experiences and videos, go to [www.automaticfeeding.com](http://www.automaticfeeding.com)

# STATIONARY MIXERS FOR SILAGE

Stationary mixer feeders with a capacity of 7-52 m<sup>3</sup> (250-1,860 cu.ft.)



Solomix 3 STAT

Mixing at a fixed location

*The advantage of stationary mixer feeders is that they are powered by electricity, enabling you to save on fuel costs.*

In large farms where the feeding stations are spread over a large area, it can be advantageous to mix the feed in a central location and then to discharge it using a delivery truck.

A stationary mixer feeder can also be a great solution on small farms, e.g. if you want to dispense feed using a conveyor belt system or if there is no room on the feeding alley for a mixer wagon. We offer stationary mixer feeders with a capacity of 7-52 m<sup>3</sup> (250-1,860 cu.ft.).



Solomix 1 STAT

# STATIONARY MIXER FEEDERS FOR BIOGAS

Feeding systems for biogas digesters



Solomix 3 Biogas

*Do you think it is important to use alternative energy sources? If so, have you considered purchasing a biogas installation for generating energy?*

It is becoming increasingly important to use alternative energy sources. With the help of a biogas installation, manure can be converted into biogas, which is used as a fuel in heating plants or is converted into green gas.

With a biogas installation you can follow a clean, scientifically proven path to achieving power generation and power supply. Our vertical mixers are perfect for adding solids. We offer a full range of stationary mixers as feeding systems for biogas digesters - available in capacities of 10-80 m<sup>3</sup> (360-2,860 cu.ft.).

Our biogas feeding systems are available in capacities of 10-80 m<sup>3</sup> (360-2,860 cu.ft.).



Triocot liner

# TFM TRACKER FEED MANAGEMENT SOFTWARE & TRIOTRONIC WEIGHING SYSTEMS

*Get a grip on your feed costs*



Triotronic 7600T

*Balanced rations are the secret to a healthy herd and high-quality, high-value production. The trick is to measure out the best ration every day, exactly as it was conceived on paper.*

A feed management program compares the rations determined in advance with the amount of feed actually delivered. With this data you, as a livestock farmer, can see exactly where the difference lies and thus where improvements can be made. You are given insight into the forage and feed concentrate costs compared to yield. Using these insights you can then start to make strategic adjustments and feed your livestock more accurately. This allows for savings in feed costs of about 4% per day.

Feed components, rations, animal groups and information about the mixer feeder are fed into the computer and can then be exchanged via a USB stick or via WiFi with the weighing computer on the mixer wagon. You can see at a glance how much feed has actually been loaded and fed compared to the planned ration.



Triomaster S





More accurate feeding

You will therefore know exactly what the dry matter intake is per cow. This allows you to make adjustments in good time. We have three feed management programs in our product range. We offer special packages for dairy farmers, beef farmers and feed contractors. All three of these packages offer a total solution for controlling feed costs at the same time as improving feed efficiency and milk production. The TFM Tracker™ Dairy (dairy cattle) is available from the basic version up to a PRO+ version and can also easily be upgraded.

### A WEIGHING SYSTEM IS ESSENTIAL

A weighing system is essential to be able to load the correct quantities of feed. Our Triotronic weighing system has been designed for maximum accuracy with three weighing bars, two of which are assembled on the wheel axles and one on the drawbar. The weight is read from the weight indicators on the mixer feeder or, combined with the programmable Triotronic 7600T weighing computer, wirelessly via an app or via a cab control in the cabin of the loading vehicle.



## CAPACITY AND MIXING QUALITY WERE THE DECIDING FACTORS

*Cock Verweij is a dairy farmer and cheesemaker. Together with his two brothers, he runs the family business. Their 400 dairy cows produce around 10,000 kg (22,046 Lbs.) of Gouda cheese a week.*

When the stables were rebuilt in 2014, Verweij decided to implement an automatic feeding system. Cock Verweij: “The capacity of the Triomatic system was the deciding factor for me. We feed the dairy cows 18 times a day and the other groups 12 times. If we didn’t have such a feeding robot, we would have to hire extra personnel. But even then, we wouldn’t have the flexibility we have now. In the past,

we would feed four loads a day using a mixer feeder, which meant we were losing about six hours per day. Now all we need to do is fill up the feed kitchen. This takes us a total of 12 hours a week, which includes the silage work and adapting the rations.” Feeding continues as normal on weekends without the need for anyone to oversee operations. Verweij: “This makes us enormously flexible as we can now utilise this time saved to do other things. Another advantage is that we can easily adapt the feeding to the weather conditions, for example. If the weather is very hot during the day, we set the feeding periods so that less feed is served.

# THANKS TO THE EXCELLENT MIXING RESULTS, WE NOW NEED MUCH LESS CONCENTRATE FEED THAN WE USED TO

Cock Verweij | Dairy farmer and cheesemaker

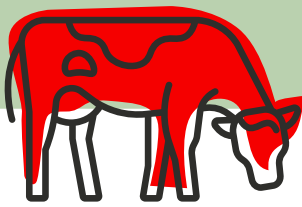

**400 dairy cows**

After it cools down in the evening, a higher quantity or extra feeding period can be activated. In this way, we can optimally respond to circumstances and to the cows' needs."

Thanks to this higher feeding frequency and the freshness of the feed, the cows are able to absorb more nutrients from the feed. More regular and structured feeding leads to better digestion and helps the cow's rumen function properly. The stable is also kept quieter as the cattle are offered feed several times a day. "Since implementing the Triomatic system, the stables are quiet and our feeding efficiency has increased considerably. The robot mixes exceptionally well, the cows can't be selective and that translates to better returns. Thanks to the excellent mixing results, we now need much less concentrate feed than we used to."



For more user experiences and information about automatic feeding go to [www.automaticfeeding.com](http://www.automaticfeeding.com)





## SERVICE & MAINTENANCE

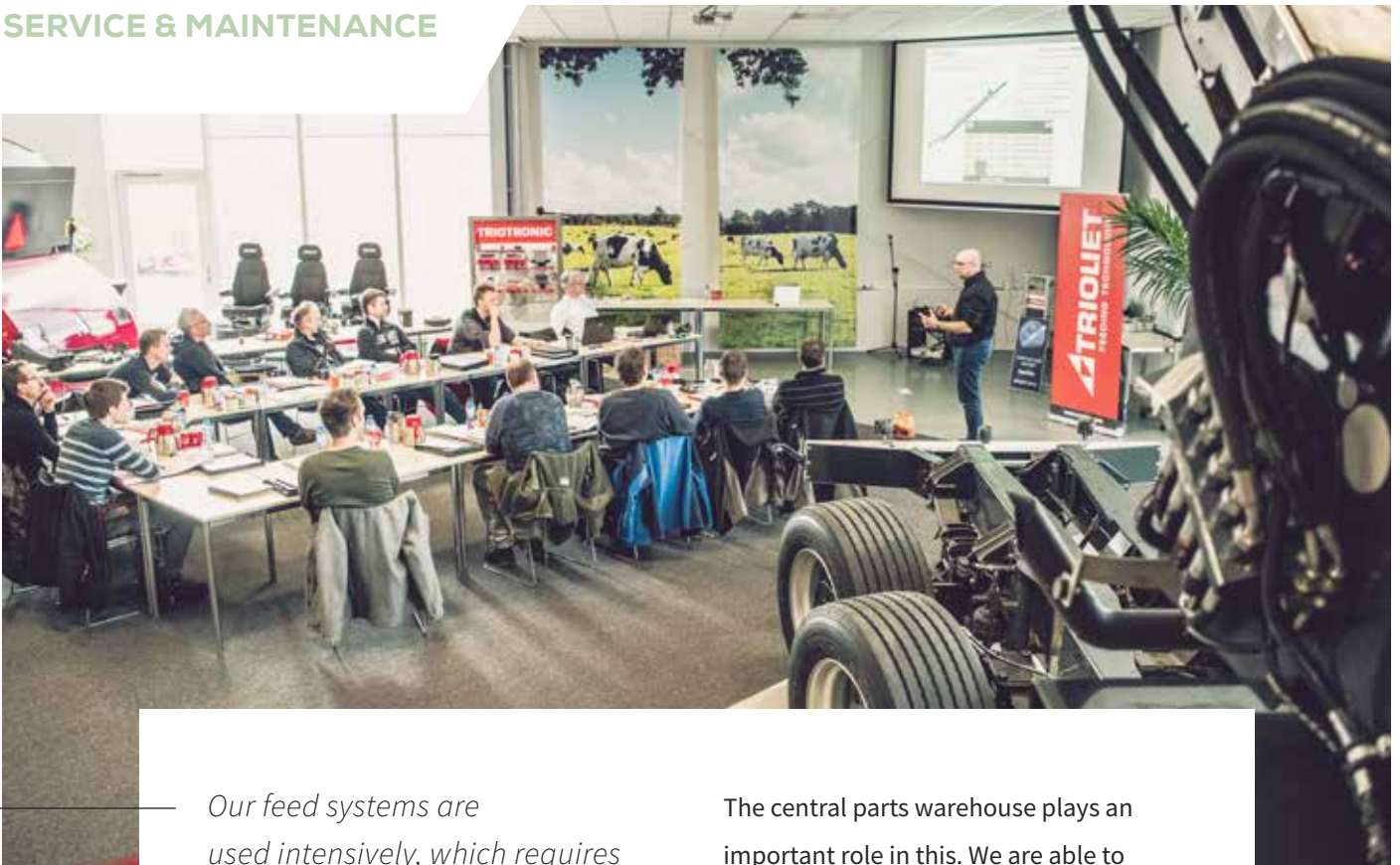

*Our feed systems are used intensively, which requires periodic maintenance. To be able to quickly service your requirements, we have an extensive worldwide network of dealers. They are ready to advise and assist as required.*

From our head office in the Netherlands, our own service engineers and fitters offer support to the dealers.

The central parts warehouse plays an important role in this. We are able to supply (spare) parts all over the world within 24 hours both from the head office in the Netherlands and from our warehouses in the United States, Canada and China. Our dealers periodically undergo training so they are always up to date with the most recent developments. Fitters and sellers come to our head office from all over the world for technical and commercial training sessions at the Trioliet Training Centre.





## ABOUT TRIOLIET

*The three 'trio' Liet brothers set up Trioliet in 1950. In just over 75 years our family business has grown into a global player.*





As you can see, we are a total supplier of premium feed technology. Every day thousands of cows all over the world are fed with our machines. In just over 75 years our family business has grown into a global player. We view it as our duty to provide sustainable premium solutions around the world for the mechanised and automated feeding of cattle on professional farms. That means that designing new solutions and optimising existing technologies are our highest priorities. We are able to offer made-to-measure solutions for cattle farms throughout the world. To do this, we draw on our extensive product range. We hope to be able to be of service to you too.



**Robert Liet**

## TRIOLIET SALES ORGANISATION

| Country                      | Importer/Sales region                             | Contact                 |
|------------------------------|---|-------------------------|
| United Kingdom               | UK North  | Jamie Brett             |
|                              | UK South  | Martyn Northover        |
| Ireland                      | TRIOLIET BV                                       | Padraig O'kane          |
| USA                          | USA West  | Ben Meinen              |
|                              | USA Mid-West                                      | Alan Brandmeyer         |
|                              | USA Upper Mid-West                                | Hans Lambers            |
|                              | USA East  | Alfred Kamps            |
| Australia                    | TRIOLIET BV                                       | Glen Williams           |
| Canada                       | Canada West                                       | Ben Meinen              |
|                              | Canada East                                       | David Good              |
|                              | Quebec  | Andre Trepanier         |
| Brazil                       | Bouwman Tecnologia                                | Bernard Bouwman         |
| Chili                        | Ferosor Agricola S.A.                             | Guido Scheel            |
| China                        | TRIOLIET BV                                       | Ran Long                |
| Cyprus                       | Kakkis Agrifuture Products LTD                    | Philippos Kakkis        |
| Denmark                      | Stenderup A/S                                     | Mogens Jensen           |
| Finland                      | Hankkija  | Jarmo Syrjälä           |
| France                       | TRIOLIET BV                                       | J. Reulink              |
| Germany                      | TRIOLIET BV                                       | Harry Kleverkamp        |
| Greece                       | Sylco Hellas K. Syleos S.A.                       |                         |
| Iceland                      | Landstólpi ehf.                                   | Sævar Örn Gíslason      |
| India                        | TRIOLIET BV                                       | Mark Kroese             |
| Italy                        | TRIOLIET BV                                       | Guillermo Keegan        |
| Japan                        | Vicon Japan k.k.                                  | Yasuto Mori             |
| Mexico                       | Power Mix de Mexico,<br>S.A. de C.V. SOFOM E.N.R. | Salvador Becerra Martin |
| The Netherlands              | TRIOLIET BV                                       | H. Kleverkamp           |
| New Zealand                  | TRIOLIET BV                                       | Glen Williams           |
| Norway                       | Ålgård Landbrukscenter AS                         |                         |
| Paraguay                     | COTRIPAR S.A.                                     | Bruno Vefago            |
| Portugal                     | Ausama SA   | Ricardo Marques         |
| Romania                      | SC Kasper Agri SRL                                | Andries Kasper          |
| Saudi Arabia and UA Emirates | ARTAT Enterprise                                  | Loay Abiad              |
| Spain                        | Ausama SL   | Moncho Vidal Lopez      |
| Sweden                       | Trejon AB   | Johan Schols            |
| Uruguay                      | Agromaq   | Mauricio Viera          |

| <b>Telephone</b>  | <b>Website</b>               | <b>Email</b>  |
|---|------------------------------|---|
| (+44) 7796 691716<br>(+44) 7788 139391                                      | www.trioliet.com             | j.brett@trioliet.com<br>m.northover@trioliet.com  |
| (+44) 07850 989 498   | www.trioliet.com             | p.okane@trioliet.com  |
| (+1) 604 3789931<br>(+1) 661 3033626<br>(+31) 620248187<br>(+1) 407 2579011 | www.trioliet.us              | b.meinen@trioliet.com<br>albrandmeyer@hotmail.com<br>h.lambers@trioliet.com<br>a.kamps@trioliet.com |
| (+64) 216 08093   | www.trioliet.com             | g.williams@trioliet.com   |
| (+1) 604 3789931<br>(+1) 5199432432<br>(+1) 819 444 8231                    | www.trioliet.com             | b.meinen@trioliet.com<br>d.good@trioliet.com<br>a.trepanier@trioliet.com                            |
| (+55) 423 234 1132  | www.bouwman.com.br           | bernardo@bouwman.com.br   |
| (+56) 642 269215  | www.ferosor.cl               | gscheel@ferosor.cl  |
| (+86) 1391 1734 350<br>(+357) 99 622053                                     | www.trioliet.cn              | r.long@trioliet.com<br>info@kakkisagrifuture.com  |
| (+45) 70 10 61 91   | www.stenderup.eu             | info@stenderup.eu   |
| (+358) 503 705 094  | www.hankkija.fi              | jarmo.syrjala@hankkija.fi   |
| (+31) 541 572121  | www.trioliet.fr              | j.reulink@trioliet.com  |
| (+31) 541 572121  | www.trioliet.de              | h.kleverkamp@trioliet.com   |
| (+30) 2310 51 51 22   |                              | nikos@sylco.gr  |
| (+354) 695 2342   | www.landstolpi.is            | saear@landstolpi.is   |
| (+31) 541 572121  | www.trioliet.com             | m.kroese@trioliet.com   |
| (+39) 39 222 16980  | www.trioliet.com             | g.keegan@trioliet.com   |
| (+81) 123 26 22 41  | www.viconjapan.com           |   |
| (+52) 871 719 00 00   | www.serviciosagromex.com.mx  | direccion@serviciosagromex.com.mx   |
| (+31) 541 572121  | www.trioliet.nl              | h.kleverkamp@trioliet.com   |
| (+64) 216 08093   | www.trioliet.com             | g.williams@trioliet.com   |
| (+47) 51 61 19 40   | www.algardlandbrukssenter.no | post@alg-land.no  |
| (595) 983 506990  |                              | bruno.vefago@cotripar.com.py  |
| (+351) 964 36 61 59   |                              | comercial@ausamasl.com  |
| (+40) 749 075 414   | www.kasper-agri.ro           | kasper@kasper-agri.ro   |
| (+966) 54 228 6011  |                              | loayabiad@artat.com.sa  |
| (+34) 986 585726  | www.ausama.es                | comercial@ausamasl.com  |
| (+46) 706 767603  | www.trejon.se                | johan.schols@trejon.se  |
| (+598) 434 21526  | www.agromaq.com.uy           | Mauricio@agromaq.com.uy   |



**TRIOLIET.COM**

Trioliet. Invents for you.

**TRIOLIET BV**

Kleibultweg 59

NL-7575 BW Oldenzaal

The Netherlands

T (+31) 541 - 57 21 21

F (+31) 541 - 57 21 25

info@trioliet.com